

SERVICE MANUAL

T7.220 / T7.235 / T7.250 / T7.260 / T7.270

Auto Command™ Tractor

T7.220 / T7.235 / T7.250 / T7.260

Power Command™ Tractor

Part number 47524342

English

June 2013

Replaces part number 84476222A



Link Product / Engine

Product	Market Product	Engine
T7.220 Power Command	North America	F4DFE613L*A
T7.235 Power Command	North America	F4DFE613K*A
T7.250 Power Command	North America	F4DFE613J*A
T7.260 Power Command	North America	F4DFE613H*A
T7.235 AutoCommand	North America	F4DFE613K*A
T7.250 AutoCommand	North America	F4DFE613J*A
T7.260 AutoCommand	North America	F4DFE613H*A
T7.270 AutoCommand	North America	F4DFE613G*A

Contents

INTRODUCTION

Engine.....	10
[10.001] Engine and crankcase	10.1
[10.102] Pan and covers	10.2
[10.216] Fuel tanks	10.3
[10.210] Lift pump and lines	10.4
[10.218] Fuel injection system.....	10.5
[10.250] Turbocharger and lines.....	10.6
[10.254] Intake and exhaust manifolds and muffler	10.7
[10.500] Selective Catalytic Reduction (SCR) exhaust treatment.....	10.8
[10.400] Engine cooling system	10.9
[10.414] Fan and drive	10.10
[10.408] Oil cooler and lines.....	10.11
Transmission.....	21
[21.113] Powershift transmission	21.1
[21.155] Powershift transmission internal components.....	21.2
[21.160] Creeper	21.3
[21.166] Overdrive.....	21.4
[21.504] Continuously Variable Transmission (CVT)	21.5
[21.505] Continuously Variable Transmission (CVT) external controls.....	21.6
[21.506] Continuously Variable Transmission (CVT) lubrication system	21.7
[21.507] Continuously Variable Transmission (CVT) internal components	21.8
[21.109] Transmission cooler and lines.....	21.9
Four-Wheel Drive (4WD) system	23
[23.202] Electro-hydraulic control	23.1
[23.314] Drive shaft.....	23.2
Front axle system	25

[25.100] Powered front axle	25.1
[25.102] Front bevel gear set and differential	25.2
[25.108] Final drive hub, steering knuckles, and shafts	25.3
[25.122] Axle suspension control	25.4
Rear axle system.....	27
[27.100] Powered rear axle.....	27.1
[27.106] Rear bevel gear set and differential	27.2
[27.120] Planetary and final drives	27.3
Power Take-Off (PTO).....	31
[31.101] Rear mechanical control	31.1
[31.104] Rear electro-hydraulic control.....	31.2
[31.114] Two-speed rear Power Take-Off (PTO)	31.3
[31.116] Three-speed rear Power Take-Off (PTO)	31.4
[31.119] Four-speed rear Power Take-Off (PTO).....	31.5
[31.146] Front Power Take-Off (PTO)	31.6
Brakes and controls	33
[33.202] Hydraulic service brakes	33.1
[33.110] Parking brake or parking lock	33.2
[33.220] Trailer brake hydraulic control.....	33.3
[33.224] Trailer brake pneumatic control	33.4
[33.350] Anti-lock Brake System (ABS)	33.5
Hydraulic systems.....	35
[35.000] Hydraulic systems.....	35.1
[35.300] Reservoir, cooler, and filters.....	35.2
[35.106] Variable displacement pump	35.3
[35.102] Pump control valves.....	35.4
[35.105] Charge pump.....	35.5
[35.322] Regulated/Low pressure system	35.6

[35.204] Remote control valves	35.7
[35.220] Auxiliary hydraulic pump and lines	35.8
[35.114] Three-point hitch control valve	35.9
[35.160] Front hitch controls and lines	35.10
[35.162] Front hitch cylinders and lines	35.11
Pneumatic system	36
[36.100] Pneumatic system.....	36.1
Hitches, drawbars, and implement couplings.....	37
[37.120] Rear three-point hitch linkage.....	37.1
[37.162] Front hitch.....	37.2
[37.110] Rear three-point hitch	37.3
[37.106] Automatic pickup hitch	37.4
Frames and ballasting	39
[39.100] Frame	39.1
Steering.....	41
[41.101] Steering control	41.1
[41.106] Tie rods.....	41.2
[41.200] Hydraulic control components.....	41.3
[41.216] Cylinders	41.4
[41.432] Autoguidance steering	41.5
Wheels.....	44
[44.511] Front wheels.....	44.1
[44.520] Rear wheels.....	44.2
Cab climate control	50
[50.100] Heating	50.1
[50.104] Ventilation	50.2
[50.200] Air conditioning.....	50.3
Electrical systems	55

- [55.610] Ground speed control 55.1
- [55.000] Electrical system 55.2
- [55.100] Harnesses and connectors..... 55.3
- [55.015] Engine control system..... 55.4
- [55.301] Alternator..... 55.5
- [55.302] Battery..... 55.6
- [55.988] Selective Catalytic Reduction (SCR) electrical system 55.7
- [55.640] Electronic modules..... 55.8
- [55.513] Cab transmission controls..... 55.9
- [55.024] Transmission control system..... 55.10
- [55.020] Transmission speed sensors..... 55.11
- [55.021] Transmission pressure sensors 55.12
- [55.022] Transmission temperature sensors 55.13
- [55.045] Front axle control system 55.14
- [55.048] Rear Power Take-Off (PTO) control system 55.15
- [55.049] Front Power Take-Off (PTO) control system 55.16
- [55.031] Parking brake electrical system 55.17
- [55.035] Remote control valve electric control 55.18
- [55.051] Cab Heating, Ventilation, and Air-Conditioning (HVAC) controls..... 55.19
- [55.050] Heating, Ventilation, and Air-Conditioning (HVAC) control system..... 55.20
- [55.047] Steering control system 55.21
- [55.523] Cab hitch controls 55.22
- [55.130] Rear three-point hitch electronic control system 55.23
- [55.911] Global Positioning System (GPS) 55.24
- [55.680] Autopilot/Autoguidance 55.25
- [55.408] Warning indicators, alarms, and instruments 55.26
- [55.350] Anti-lock Brake System (ABS) electrical system..... 55.27
- [55.032] Trailer brake electrical system 55.28
- [55.030] Service brake electrical system 55.29

[55.DTC] FAULT CODES.....	55.30
Platform, cab, bodywork, and decals.....	90
[90.100] Engine hood and panels	90.1
[90.150] Cab.....	90.2



INTRODUCTION

Contents

INTRODUCTION

Advice - Important notice regarding equipment servicing	3
Foreword - How to use and navigate through this manual	4
Safety rules	9
Safety rules	10
Torque - Minimum tightening torques for normal assembly	12
Torque - Standard torque data for hydraulics	17
General specification - Biodiesel Fuels	19
Capacities	20
<small>T7.220-270 AutoCommand, T7.220-260 Power Command</small>	
Consumables Lubrications and Coolants	21

Advice - Important notice regarding equipment servicing

All repair and maintenance work listed in this manual must be carried out only by qualified dealership personnel, strictly complying with the instructions given, and using, whenever possible, the special tools.

Anyone who performs repair and maintenance operations without complying with the procedures provided herein shall be responsible for any subsequent damages.

The manufacturer and all the organizations of its distribution chain, including - without limitation - national, regional, or local dealers, reject any responsibility for damages caused by parts and/or components not approved by the manufacturer, including those used for the servicing or repair of the product manufactured or marketed by the manufacturer. In any case, no warranty is given or attributed on the product manufactured or marketed by the manufacturer in case of damages caused by parts and/or components not approved by the manufacturer.

The information in this manual is up-to-date at the date of the publication. It is the policy of the manufacturer for continuous improvement. Some information could not be updated due to modifications of a technical or commercial type, or changes to the laws and regulations of different countries.

In case of questions, refer to your Sales and Service Networks.

Foreword - How to use and navigate through this manual

This manual has been produced by a new technical information system. This new system is designed to deliver technical information electronically through web delivery (eTIM), DVD, and paper manuals. A coding system called SAP has been developed to link the technical information to other Product Support functions, e.g., Warranty.

Technical information is written to support the maintenance and service of the functions or systems on a customer's machine. When a customer has a concern on their machine it is usually because a function or system on their machine is not working at all, is not working efficiently, or is not responding correctly to their commands. When you refer to the technical information in this manual to resolve that customer's concern, you will find all the information classified using the SAP coding, according to the functions or systems on that machine. Once you have located the technical information for that function or system, you will then find all the mechanical, electrical or hydraulic devices, components, assemblies, and sub assemblies for that function or system. You will also find all the types of information that have been written for that function or system: the technical data (specifications), the functional data (how it works), the diagnostic data (fault codes and troubleshooting), and the service data (remove, install adjust, etc.).

By integrating SAP coding into technical information, you will be able to search and retrieve just the right piece of technical information you need to resolve that customer's concern on his machine. This is made possible by attaching 3 categories to each piece of technical information during the authoring process.

The first category is the Location, the second category is the Information Type and the third category is the Product:

- LOCATION - the component or function on the machine, that the piece of technical information is going to describe (e.g., Fuel tank).
- INFORMATION TYPE - the piece of technical information that has been written for a particular component or function on the machine (e.g., Capacity would be a type of Technical Data describing the amount of fuel held by the fuel tank).
- PRODUCT - the model for which the piece of technical information is written.

Every piece of technical information will have those three categories attached to it. You will be able to use any combination of those categories to find the right piece of technical information you need to resolve that customer's concern on their machine.

That information could be:

- the procedure for how to remove the cylinder head
- a table of specifications for a hydraulic pump
- a fault code
- a troubleshooting table
- a special tool

Manual content

This manual is divided into Sections. Each Section is then divided into Chapters. Contents pages are included at the beginning of the manual, then inside every Section and inside every Chapter. An alphabetical Index is included at the end of each Chapter. Page number references are included for every piece of technical information listed in the Chapter Contents or Chapter Index.

Each Chapter is divided into four Information types:

- Technical Data (specifications) for all the mechanical, electrical or hydraulic devices, components, assemblies or sub-assemblies.
- Functional Data (how it works) for all the mechanical, electrical or hydraulic devices, components, assemblies or sub-assemblies.
- Diagnostic Data (fault codes, electrical and hydraulic troubleshooting) for all the mechanical, electrical or hydraulic devices, components, assemblies or sub-assemblies.
- Service Data (remove disassemble, assemble, install) for all the mechanical, electrical or hydraulic devices, components, assemblies or sub-assemblies.

Sections

Sections are grouped according to the main functions or a systems on the machine. Each Section is identified by a number (00, 35, 55, etc.). The Sections included in the manual will depend on the type and function of the machine that the manual is written for. Each Section has a Contents page listed in alphabetic/numeric order. This table illustrates which Sections could be included in a manual for a particular product.

SECTION	PRODUCT					
	Tractors					
	Vehicles with working arms: backhoes, excavators, skid steers,					
	Combines, forage harvesters, balers,					
	Seeding, planting, floating, spraying equipment,					
	Mounted equipment and tools,					
00 - Maintenance	X	X	X	X	X	
05 - Machine completion and equipment	X	X	X	X	X	
10 - Engine	X	X	X	X		
14 - Main gearbox and drive	X	X	X	X		
18 - Clutch	X	X	X			
21 - Transmission	X	X	X	X		
23 - Four wheel drive (4WD) system	X	X	X	X		
25 - Front axle system	X	X	X	X		
27 - Rear axle system	X	X	X	X		
29 - Hydrostatic drive	X	X	X	X		
31 - Power Take-Off (PTO)	X		X			
33 - Brakes and controls	X	X	X	X		
35 - Hydraulic systems	X	X	X	X		
36 - Pneumatic system	X	X	X	X		
37 - Hitches, drawbars and implement couplings	X		X	X		
39 - Frames and ballasting	X	X	X	X	X	
41 - Steering	X	X	X	X		
44 - Wheels	X	X	X	X		
46 - Steering clutches						
48 - Tracks and track suspension	X	X	X			
50 - Cab climate control	X	X	X	X		
55 - Electrical systems	X	X	X	X	X	
56 - Grape harvester shaking						
58 - Attachments/headers			X			
60 - Product feeding			X			

INTRODUCTION

61 - Metering system				X	
62 - Pressing - Bale formation			X		
63 - Chemical applicators				X	
64 - Chopping			X		
66 - Threshing			X		
68 - Tying/Wrapping/Twisting			X		
69 - Bale wagons					
70 - Ejection			X		
71 - Lubrication system	X	X	X	X	X
72 - Separation			X		
73 - Residue handling			X		
74 - Cleaning			X		
75 - Soil preparation/Finishing					
76 - Secondary cleaning / Destemmer					
77 - Seeding				X	
78 - Spraying				X	
79 - Planting				X	
80 - Crop storage / Unloading			X		
82 - Front loader and bucket	X	X			
83 - Telescopic single arm	X	X			
84 - Booms, dippers and buckets	X	X			
86 - Dozer blade and arm	X	X			
88 - Accessories	X	X	X	X	X
89 - Tools	X	X	X	X	X
90 - Platform, cab, bodywork and decals	X	X	X	X	

Chapters

Each Chapter is identified by a number e.g. Engine - Engine and crankcase - 10.001. The first number is identical to the Section number i.e. Chapter 10.001 is inside Section 10, Engine. The second number is representative of the Chapter contained within the Section.

CONTENTS

The Chapter Contents lists all the technical data (specifications), functional data (how it works), diagnostic data (fault codes and troubleshooting), and service data (remove, install, adjust, etc.), that have been written in that Chapter for that function or system on the machine.

Contents

	ENGINE	
	ENGINE - Engine and crankcase – 10.001	
TECHNICAL DATA		
ENGINE - Engine and crankcase - General specification (10.001 - D.40.A.10)		4
FUNCTIONAL DATA		
ENGINE - Engine and crankcase - Dynamic description (10.001 - C.30.A.10)		6
SERVICE		
ENGINE - Engine and crankcase - Remove (10.001 -F.10.A.10)		8
DIAGNOSTIC		
ENGINE - Engine and crankcase - Troubleshooting (10.001 - G.40.A.10)		10

INDEX

The Chapter Index lists in alphabetical order all the types of information (called information units) that have been written in that Chapter for that function or system on the machine.

Index

	ENGINE - 10	
	ENGINE	
ENGINE - Engine and crankcase - Dynamic description (10.001 - C.30.A.10)		6
ENGINE - Engine and crankcase - General specification (10.001 - D.40.A.10)		4
ENGINE - Engine and crankcase - Remove (10.001 -F.10.A.10)		8
ENGINE - Engine and crankcase - Troubleshooting (10.001 - G.40.A.10)		10

Information units and information search

Each chapter is composed of information units. Each information unit has the SAP code shown in parentheses. This indicates the function and type of information in that information unit. Each information unit has a page reference within that Chapter. The information units provide a quick and easy way to find just the right piece of technical information you are looking for.

Example information unit	Engine block cover - Front – Remove (10.102.AP.01 - F.10.A.10)					
Information Unit SAP code	10	102	AK	01	F	10.A.10
SAP code classification	Engine	Pan and covers	Engine block cover	Front cover	Service data	Remove

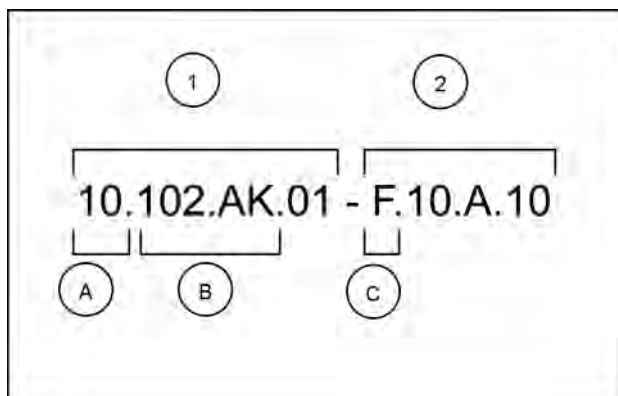

NHIL12GEN0070A 1

Navigate to the correct information unit you are searching for by identifying the function and information type from the SAP code.

- **(1)** Location and **(2)** Information type.
- **(A)** corresponds to the sections of the service manual.
(B) corresponds to the chapters of the service manual. After **(B)** there may be some additional information. In this case it shows “.01”, which represents the “Front” block cover. These options may be front/rear, left/right, hydraulic/mechanical etc.
(C) corresponds to the type of information listed in the chapter contents: Technical Data, Functional Data, Diagnostic, or Service.
(A) and **(B)** are also shown in the page numbering on the page footer.
THE REST OF THE CODING IS NOT LISTED IN ALPHANUMERIC ORDER IN THIS MANUAL.
- You will find a table of contents at the beginning and end of each section and chapter.
You will find an alphabetical index at the end of each chapter.
- By referring to **(A)**, **(B)** and **(C)** of the coding, you can follow the contents or index (page numbers) and quickly find the information you are looking for.

Page header and footer

The page header will contain the following references:

- Section and Chapter description

The page footer will contain the following references:

- Publication number for that Manual.
- Version reference for that publication.
- Publication date
- Section, chapter, and page reference e.g. 10.102 / 9

Safety rules

Personal safety



This is the safety alert symbol. It is used to alert you to potential personal injury hazards. Obey all safety messages that follow this symbol to avoid possible death or injury.

Throughout this manual and on machine decals, you will find the signal words DANGER, WARNING, and CAUTION followed by special instructions. These precautions are intended for the personal safety of you and those working with you.

Read and understand all the safety messages in this manual before you operate or service the machine.

! DANGER indicates a hazardous situation which, if not avoided, will result in death or serious injury. The color associated with DANGER is RED.

! WARNING indicates a hazardous situation which, if not avoided, could result in death or serious injury. The color associated with WARNING is ORANGE.

! CAUTION, used with the safety alert symbol, indicates a hazardous situation which, if not avoided, could result in minor or moderate injury. The color associated with CAUTION is YELLOW.

FAILURE TO FOLLOW DANGER, WARNING, AND CAUTION MESSAGES COULD RESULT IN DEATH OR SERIOUS INJURY.

Machine safety

NOTICE: Notice indicates a situation which, if not avoided, could result in machine or property damage. The color associated with Notice is BLUE.

Throughout this manual you will find the signal word Notice followed by special instructions to prevent machine or property damage. The word Notice is used to address practices not related to personal safety.

Information

NOTE: Note indicates additional information which clarifies steps, procedures, or other information in this manual.

Throughout this manual you will find the word Note followed by additional information about a step, procedure, or other information in the manual. The word Note is not intended to address personal safety or property damage.

Safety rules

⚠ WARNING

Equipment rolling hazard!

Firmly apply the handbrake and place the shuttle lever in the park brake position. Stop the engine before leaving the machine. The transmission will not prevent the machine from rolling when the engine is shut off.

Failure to comply could result in death or serious injury.

W0378A

⚠ WARNING

Improper operation or service of this machine can result in an accident.

Before working on any part of the electrical system, disconnect the battery ground cable. Complete all electrical work before connecting the cable.

Failure to comply could result in death or serious injury.

W0137A

⚠ WARNING

Crushing hazard!

The wheels on this vehicle are very heavy. Always use a wheel remover or chain hoists to remove and install the wheels. Use an assistant as required.

Failure to comply could result in death or serious injury.

W0149A

⚠ WARNING

Jack stands can slip or fall over. Dropping, tipping, or slipping of machine or its components is possible.

DO NOT work under a vehicle supported by jack stands only. Park machine on a level surface. Block wheels. Support machine with safety stands.

Failure to comply could result in death or serious injury.

W0069A

⚠ WARNING

Fire hazard!

When handling diesel fuel, observe the following precautions:

1. Do not smoke.
2. Never fill the tank when the engine is running.
3. Wipe up spilled fuel immediately.

Failure to comply could result in death or serious injury.

W0099A

⚠ WARNING

Escaping fluid!

Hydraulic fluid or diesel fuel leaking under pressure can penetrate the skin and cause infection or other injury. To prevent personal injury: Relieve all pressure before disconnecting fluid lines or performing work on the hydraulic system. Before applying pressure, make sure all connections are tight and all components are in good condition. Never use your hand to check for suspected leaks under pressure. Use a piece of cardboard or wood for this purpose. If injured by leaking fluid, see your doctor immediately.

Failure to comply could result in death or serious injury.

W0178A

⚠ WARNING

Fire hazard!

Do not add gasoline, alcohol, or blended fuels to diesel fuel, except as recommended in this manual. Fuel combinations may increase fire and explosion hazards.

Failure to comply could result in death or serious injury.

W0401A

⚠ WARNING

Personal Protective Equipment (PPE) required.

When assembling, operating, or servicing the machine, wear protective clothing and PPE necessary for the particular procedure. Some PPE that may be necessary includes protective shoes, eye and/or face protection, hard hat, heavy gloves, filter mask, and hearing protection.

Failure to comply could result in death or serious injury.

W0353A

Torque - Minimum tightening torques for normal assembly

METRIC NON-FLANGED HARDWARE

NOM. SIZE	CLASS 8.8 BOLT and CLASS 8 NUT		CLASS 10.9 BOLT and CLASS 10 NUT		LOCKNUT CL.8 W/CL8.8 BOLT	LOCKNUT CL.10 W/CL10.9 BOLT
	UNPLATED	PLATED W/ZnCr	UNPLATED	PLATED W/ZnCr		
M4	2.2 N·m (19 lb in)	2.9 N·m (26 lb in)	3.2 N·m (28 lb in)	4.2 N·m (37 lb in)	2 N·m (18 lb in)	2.9 N·m (26 lb in)
M5	4.5 N·m (40 lb in)	5.9 N·m (52 lb in)	6.4 N·m (57 lb in)	8.5 N·m (75 lb in)	4 N·m (36 lb in)	5.8 N·m (51 lb in)
M6	7.5 N·m (66 lb in)	10 N·m (89 lb in)	11 N·m (96 lb in)	15 N·m (128 lb in)	6.8 N·m (60 lb in)	10 N·m (89 lb in)
M8	18 N·m (163 lb in)	25 N·m (217 lb in)	26 N·m (234 lb in)	35 N·m (311 lb in)	17 N·m (151 lb in)	24 N·m (212 lb in)
M10	37 N·m (27 lb ft)	49 N·m (36 lb ft)	52 N·m (38 lb ft)	70 N·m (51 lb ft)	33 N·m (25 lb ft)	48 N·m (35 lb ft)
M12	64 N·m (47 lb ft)	85 N·m (63 lb ft)	91 N·m (67 lb ft)	121 N·m (90 lb ft)	58 N·m (43 lb ft)	83 N·m (61 lb ft)
M16	158 N·m (116 lb ft)	210 N·m (155 lb ft)	225 N·m (166 lb ft)	301 N·m (222 lb ft)	143 N·m (106 lb ft)	205 N·m (151 lb ft)
M20	319 N·m (235 lb ft)	425 N·m (313 lb ft)	440 N·m (325 lb ft)	587 N·m (433 lb ft)	290 N·m (214 lb ft)	400 N·m (295 lb ft)
M24	551 N·m (410 lb ft)	735 N·m (500 lb ft)	762 N·m (560 lb ft)	1016 N·m (750 lb ft)	501 N·m (370 lb ft)	693 N·m (510 lb ft)

NOTE: M4 through M8 hardware torque specifications are shown in pound-inches. M10 through M24 hardware torque specifications are shown in pound-feet.

**Thanks very much for your reading,
Want to get more information,
Please click here, Then get the complete
manual**

JustClickHere 

NOTE:

**If there is no response to click on the link above,
please download the PDF document first, and then
click on it.**

**Have any questions please write to me:
admin@servicemanualperfect.com**